

SDN

System for remote power feeding over multiple copper pairs

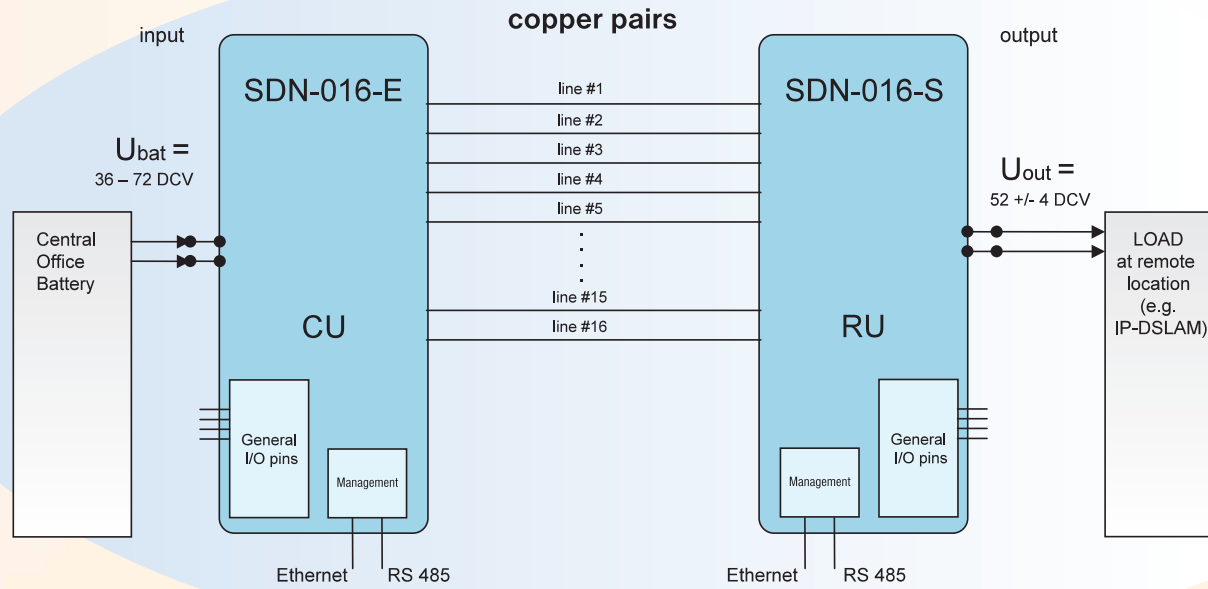

Trends in Telecommunications and related problems

The demand for bandwidth in copper access network is expanding exponentially and thus putting high pressure on existing networks. For sure fibre can provide the best answer for bandwidth-hungry applications, however it is also a capital-hungry and time consuming solution. Telecom operators can not afford to wait for the »final solution«. The »solution today« is to bring the edge of the network to remote locations, closer to end customers. In this case copper pairs can deliver enough bandwidth for today's need (triple play).

Installing the edge equipment (e.g. DSLAMs) closer to end-users has one major problem: how to power the remote equipment? When providing electricity supply one always faces many problems: construction and safety problems, local authority's permissions, building permits, private property legal problems, electricity counters installation, charging & billing. etc And it is even more difficult to ensure uninterrupted power supply (UPS) which on top of everything needs regular maintenance!

Description of SDN-016 Powering system

The solution is to use SDN Remote Powering System to provide power from existing edge points (e.g. central offices, existing street cabinets....) where uninterrupted power supply is already available. SDN system uses up to 16 copper pairs in order to provide up to 200 W on 48 VDC on remote location, using 48 VDC source in Central Office.

System consists of two units: Central-office Unit (CU) unit which connects to 48 VDC power source (UPS) in Central Office or similar place and Remote Unit (RU) unit which is installed on remote premises in small street cabinet or similar. Up to 16 parallel copper pairs are used to transport the power from CU to RU. The system is built modularly, meaning for each pair there is a dedicated module on CU and RU which may be omitted if less than 16 copper pairs are available or lesser power is needed. Range of transported power is from 15 to 200 W. Both units fit into standard 19" rack with 1 HU height.

Technology used in SDN System

48 VDC from Central office side is transported in the most efficient way over up to 16 pairs to remote side, strictly following safety standards EN60950 and EN60950-21. Control circuits on RU constantly regulate input currents on all lines in order to adapt to load changes and provide minimum losses on the line. Output current limiter on RU protects the unit and equipment from in-rush currents. Ethernet and RS-485 ports are available for management and supervision of the system. Additional general purpose input/output pins are available for optional sensors and/or activators.



TECHNICAL CHARACTERISTICS

SDN-016-S (RU)

- Input
 - Max. number of line used (inputs) 16
 - Max. current on the line 55 mA
 - Typical input voltage 300 VDC
- Output
 - Max. out power 200 W
 - Max. efficiency 75%
 - Output voltage 52 VDC \pm 4 V
- Earthing
 - Earthing connection 4-pole connector (+ or - , user selectable)



SDN-016-E (CU)

- Output
 - Max. number of lines used for powering (outputs) 16
 - Max. current on the line 60 mA
 - Typical output voltage 300 VDC
- Input
 - Input voltage range from 36 VDC to 72 VDC
 - Max. input power 400 W
 - Max. efficiency (SDN-16E) 75%
- Earthing
 - Earthing connection + pole grounded

SDN-016 system

- Standards
 - Safety EN60950, EN60950-21
 - EMC EN55022 class B, ETSI EN 300386
- Operating temperature range
 - Min./max. ambient temperature at relative humidity 0% - 95%, without condensation -20°C to 50°C
- Dimensions
 - Height 44 mm (1HU)
 - Width 482 mm (19")
 - Depth 167 mm
- Management and control
 - Ethernet RJ-45
 - RS485 RJ-11, galvanic isolated interface, with additional galvanic isolated power supply for power feeding of extern sensor units (8-12 VDC, 1 W, 1500 VDC insulation voltage).
 - Digital inputs (2) Max. voltage 80 DCV, max. control current 2 mA (internally limited), galvanic isolated
 - Digital outputs (2) 300 VDC, max. current 100 mA, galvanic isolated
- Management system (option)
 - Ethernet interface Ethernet 10 Mbps, HTTP, SNMP v1, RJ-45
 - Communication interface 2 (option) RS-485, RJ-11
 - Information/commands available over HTTP and SNMP Number of powering copper pairs available, number of powering copper pairs in operation, values of input/output currents and voltages, temperature inside of the unit, status of digital input pins, control of digital output pins.
- Optional features With additional control modules, which communicate via RS 485 is possible to supervise additional parameters like: Room temperature, water outflow etc.

