

D2500

TELECOM ANALYZER



ISDN & Telecom standards

On board support for multiple protocols

WAN & DATACOM

Leased line & Datacom Pre-Qualification Testing

Flexible Operation

Control all Functions locally
or via Remote Control

OVERVIEW

The D2500 Telecom Analyzer is the culmination of thirty years of experience that Aethra has in the development and production of test instruments. It has been designed to meet the requirements of technicians working in the Telecoms industry, and its range of capabilities makes it an indispensable toolkit - probably the only tester the engineer needs to carry around with him.

Integration of a wide range of features allows the D2500 to address a wider range of applications such as Service Verification over PRI, BRI, Frame Relay Links, WAN and ISDN lines, and also testing of DCE/DTE connections over a range of interfaces. Additionally, testing for G.SHDSL, HDSL and IP across the Internet is also provided. With so many interfaces and clearly defined analysis and diagnostic capabilities, the D2500 provides a complete solution for troubleshooting problems in a multi-skilled engineering environment.

The new, improved Graphical User Interface uses smart windows drop-down menus. This makes navigating around the configuration procedures extremely easy and minimizes time required to achieve proficiency with the tester.

All the information required to check line status, and any potential anomaly on the line can be quickly accessed, thanks to the Smart Status™ feature available with the press of a button.

This feature is always available - even while a test is in progress, thus allowing continuous monitoring of clock frequency, alarms, errors, PCM time-slot status, channel configurations and test parameters, as well as the unit's own device status.

FEATURES AT A GLANCE

- Onboard multi protocol analysis including full frames decoding
- Internet applications with specific tests for PPP/IP, TFTP, HTTP and FTP
- Network-qualifying tool for Frame Relay with FOX test
- Includes PC108 for Windows™ software for powerful analysis and remote management
- X.21, G.703, BRI interfaces incorporated into the main unit
- Enhanced Graphic User Interface





INTERFACES

Thanks to D2500's wide range of interfaces, coupled with its reliability, the simplicity of use, and quick deployment of its extensive features makes it one of the most versatile devices on the market.

Besides the most commonly used accesses such as PRI, BRI and POTS, the measures may be carried out also over leased circuits WAN/datacom^{3,9}.

The V.11/X.21 interface is embedded in the main unit and may be enabled by means of a software option while the V.35, V.36, V.24 and co-dir interfaces may be accessed through the VX2000 adapter.

- G.703 (2Mbps)
- G.704 (Nx64Kbps)
- ISDN Primary Access
- PCM30, PCM31
- CCS, CAS
- CRC4
- V.35³, V.36³, V.24³, and co-dir.
- V.11/X.21⁹
- ISDN Basic Access S0/T0
- ISDN Basic Access Uk0 2B1Q and 4B3T
- IDSL (64 Kbps - 128 Kbps)
- POTS⁵

MONITOR

The device includes a protocol analyzer that allows the capture of the main communication protocols over single and multiple channels. The onboard decoding allows for the analysis of traces on the spot.

The advanced analysis through the PC software¹ issued with the device, can be used for more complex problems involving connection issues or e.g user's Internet configuration settings.

The feature is available both in high impedance monitor and simulator modes.

If necessary, larger trace data may be saved on a standard MultiMediaCard™, thus extending the unit's internal memory.

- D & B channel monitor
- Layer 1 errors, alarms
- U-Bus monitor
- Capturing filters
- Statistics information
- E-DSS1, 1TR6, X.25, VN4, Q.SIG, DASS2, DPNSS, CorNet®
- V.5.1/V.5.2 decoding¹
- PPP/IP and FRAME RELAY decoding¹
- MultiMediaCard™ memory support²

BER

D2500 can be used wherever line quality testing is needed. Bit Error Rate test includes results evaluation according to G.821 and G.826 specifications.

Measurements may be carried out over all the interfaces.

Programmable thresholds can be enabled, allowing the technician to tailor the test according to local agreements or SLA's, and a clearly visible large format "OK" on the screen confirms correct functioning of the circuit under test, providing an immediate view of the line conditions and status.

The background error and alarm log allows an in-depth report, combining with the above to provide an extremely useful instrument for analysis and troubleshooting

- G.821, G.826
- Selectable test patterns
- Sync and async interfaces
- N*64k mode (full and fractional E1)
- Bearing physical layer quality test
- Multiple measurement cycles
- Test available on ISDN as well



<p>RESULT: FRAMED BER</p> <p>STOP Status: Active 1984 Kb</p> <p>SETUP Start: 02-09-2005 14:44:59 Elapsed: 00:00:21</p> <p>PRINT Bit Error Rate: 0.000</p> <p>INJECT Bits received: 42218085</p> <p>RESET Errors injected: 0</p> <p>STOP RX Errors Rx: 0</p> <p>OK! (Bit/L1 error) 1/3</p>	<p>SELECTION MENU</p> <p>← If test fails then: Disconnect</p> <p>Disconnect</p> <p>← Keep connection</p> <p>Continue</p> <p>DATA PRINT: NO Duration: Continuous</p> <p>Save setup as predefined</p>	<p>STATUS: PRIMARY RATE</p> <p>TEST CONT</p> <p>FRAME <input type="checkbox"/> SYNC</p> <p>CRC <input type="checkbox"/></p> <p>LOS <input type="checkbox"/> ALARM</p> <p>LFA <input type="checkbox"/></p> <p>RAI <input type="checkbox"/></p> <p>RAI <input type="checkbox"/></p> <p>CODE <input type="checkbox"/> ERROR</p> <p>LOCAL CRC <input type="checkbox"/></p> <p>REM CRC (E.M.U) <input type="checkbox"/></p> <p>D CHANNEL <input type="checkbox"/> I PACKET</p> <p>FAS 00000000 10011011</p> <p>NFAS 00000000 11111111 1/7</p>
---	---	---

DATACOM

The D2500 can be used to verify the quality of PCM 2Mbit and V/X streams with the ability to display the channels status, frame and multi-frame alignment words, errors and alarms.

- Tests over PCM30 and PCM31 streams
- Mono and multi-channel BER test
- Frame Relay and IP support
- Primary Rate G.703 clock frequency shift management (± 100 ppm)
- Clock measurement
- Error, alarm insertion

FRAME RELAY

Through a specific option, the D2500 may be used for installing and maintaining Frame Relay networks.

The tests can be carried out over E1, G.703 and V/X interfaces.

These are the best tools for a check of performances, end-to-end connectivity and actual load of the circuit:

- Turn-up test for verification of link connectivity and configuration
- FOX test
- IP Ping test
- QoS statistics

IP

D2500 expands its own applications field to the Internet world, thanks to two tests implemented into the standard version of the device. The first test, IP PING, enables a check of the connection to the Internet Provider, whether a remote host is reachable or not, the "IP trace routing" and the relative response times.

Moreover, progress information from



the server is provided such as negotiation messages and local/remote and server IP addresses.

This allows for checking of connection and configuration settings of the user. A further test, IP GENERATE TRAFFIC, simulates a data transfer between hosts. This test, more exhaustive than IP PING, is able to measure the throughput of the connection in progress.

- PPP, IP, UDP, ICMP, TFTP⁶
- HTTP⁸, FTP⁸ support
- Authentication PAP and CHAP (MD5)
- IP address static and dynamic
- Programmable packet length
- Testing file length up to 16Mbytes
- Multiple measurement cycles
- IP statistics and times
- Calculation of throughput in Tx/Rx path
- IP address book, password and UserID for an immediate Internet login
- No second device required to perform the test

NQTS

Network Quality Test System.

The D2500 is the first ISDN tester of its category able to provide tests for the verification of audio channels quality. It is possible to verify, whether for Basic, Primary access and POTS⁵, the typical parameters for the phonic channels such as attenuation, noise, distortion, and round trip delay (echo). This last is

very important for checking possible problems over IP networks or over networks with audio decodings particularly heavy.

The carrying out of script, through PC⁵ allows results cataloguing and analysis.

- 300 - 3400Hz voice frequency band
- Signal level generator
- RMS measurement
- Single tone or sweep mode

ISDN

The Make a Call test allows much more than the simple facility to place and receive calls. It is possible to verify the correct operation of the several supplementary services supplied by provider, such as AOC, CF, CLI, 3PTY etc.

For load testing a PBX, it is possible to generate multiple simultaneous calls with several different destination numbers and profiles, speeding up functional testing during installation of a PBX.

Where the ISDN circuit is used for data connection such as video-conferencing, the Round Trip Delay time is a critical measurement, and the D2500 provides this facility within the Make A Call test.

The integrated microphone and loudspeaker allow for the use of the device as a normal ISDN or POTS⁵ telephone.

- Speed Dial using a Directory
- ETSI supplementary services check support
- B channel round trip delay
- Multiple profiles (Speech, Data, Fax,...)
- Up to 30 active calls⁴
- B channel connected to integrated micro phone and loudspeaker or external handset or V.11 interface
- ISDN and POTS⁵ simulation

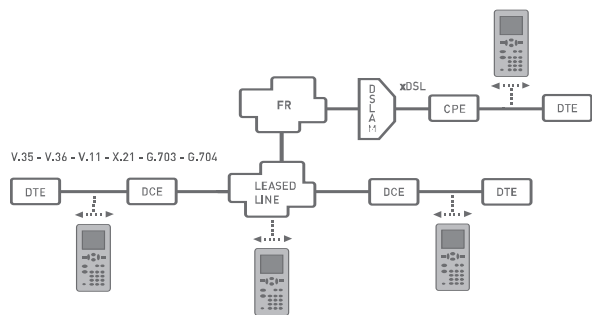

V/X INTERFACE

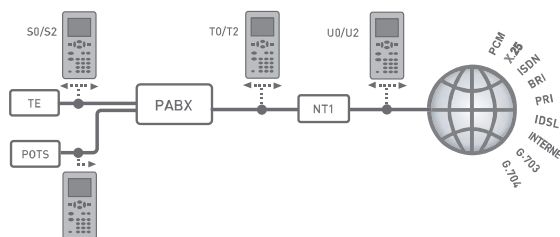

OPERATING MODES

X.25/X.31

D2500 is able to perform an X.25/X.31 connection over D channel and verify the quality of the line.

Now the test allows to simulate an X.25 traffic generation also over B channel, using programmable data packets with variable length. Statistic Data help to check out the real band of the connection and possible net congestion problems.

Through the software provided¹, it is possible to send pre-configured packets directly from the personal computer.

- D and B channel X.25/X.31 support
- DTE and DCE simulation
- Programmable transmission throughput
- Variable data packet length
- Working over Vc and Pvc circuits
- Vc and Pvc automatic recognition in incoming mode
- Traffic statistics

GENERATE TRAFFIC

This traffic simulation permits to verify the call management capabilities on behalf of the user system (PABX) or of the net.

The load simulated, may be programmed by quantity of calls to perform and duration time.

Up to 999 failure cycles are stored reporting causes and times.

- Up to 30 simultaneous calls⁴
- Programmable time between calls
- Maximum 65000 test cycles
- Settable minimum call duration
- Test cycles on connection or B channel notification



AUTOMATIC TEST

This test allows a quick and automatic verification of the line under test, both for ISDN and X.25 services.

Using default settings, the device generates a series of calls toward a remote user or to itself and verifies the complete status of the line both for BRI and PRI, checking bearer capabilities, supplementary services and B channel operation.

Alternatively, the testing can be restricted to specific elements of the above, and the configuration can be saved to create test profiles to suit different connection types.

- It is possible to set a complete automatic test or individual layers or services to verify
- Physical layer settings control
- Layer 2 configuration
- Availability status of the several bearer services, teleservices and supplementary services
- Availability checking of single B channels
- TEI and LCI detection for X.25 (X.31) service

MISCELLANEOUS

The device includes a powerful auto-answer feature for incoming calls.

The engineer can set filters to define acceptable incoming calls, perform a loop on the B Channel, or instigate a call-back to the calling party.

The Call Forward capability, and the ability to answer the incoming calls manually extend the scope of this feature in verification and stress testing of the system under test.

- Loopbox
- Call back and Call Forward Features for Single End Tests
- Programmable U-Bus load
- S/T-Bus wiring test⁷
- Protected Monitor Point (integrated amplifier)



¹ PC108 for Windows™

² MMC2000

³ VX2000

⁴ PRI

⁵ AB2000N

⁶ Requires TFTP server on remote host

⁷ WT2000

⁸ INET2500

⁹ VX21-2500

TECHNICAL SPECIFICATIONS

TELECOM INTERFACES

• Basic Rate Access	
S/T	ITU-T Rec.I.430, ETS 300 012
U	2B1Q and 4B3T, TS 102 080
• Primary Rate Access	
Interface	CCITT G.703 (2Mbps) / G.704
E1	ITU-T Rec.I.431, ETS 300 011
2Mbit	PCM30/CRC, PCM31/CRC, Unframed
• WAN / Datacom [option]	
Sync	X.21/V.11, V.24, V.35, V.36 (RS449), G.703 co-dir
Bit Rates	50bps - 2048Kbps (Nx64)
Async	V.24 (RS232)
Bit Rates	50bps - 230400bps
V.11/X.21 interface	Integrated on board (VX21-2500 option)
Clock frequency	Measurement (± 1 Hz) and shift management (± 100 ppm)

PROTOCOLS SUPPORTED

• Simulation mode	EDSS-1, Q.SIG, 1TR6, TN1R6®, VN4, X.25, X.31, DASS-2, DPNSS, CorNet®-N, -NX, -NQ, -T, PPP, IP, UDP, DHCP, ICPM, TFTP, HTTP, FTP, Frame Relay,
• Monitor mode	EDSS-1, Q.SIG, 1TR6, TN1R6®, VN4, X.25, X.31, DASS-2, DPNSS, CorNet®-N, -NX, -NQ, -T,
• Other protocols available	V.5.1, V.5.2, NI1, DMS100, 5ESS

OPERATING MODES AVAILABLE

• Basic Rate Access	BRI TE-S, BRI MON-S, BRI NT-S, BRI NT-U, BRI MON-U (D2022 option), BRI LT-U (LTU-2K option), BRI S/T-Bus wiring test (WT2000 option)
• Primary Rate Access	PRI TE-E1, PRI MON-E1, PRI MON-E1 PMP, PRI NT-E1,
• POTS/Analog	TE (AB2000N option), MON (AB2000N option)
• V/X	DTE, DCE (VX2000 and VX21-2500 option when required)
• Pattern generation	Single, n x 64Kbit timeslot

SMART STATUS™

• G.826/M.2100 (only PRI)	ES, SES, BBER, UAS
• ISDN line	Layers 1, 2, 3 and B ch status
• V/X interface	Control leads, test running, loop, clock frequency, clock phasing
• 2Mbit	FAS, NFAS, MFAS, NMFAS, alarms, errors, sync, CAS channel status,
• Frame Relay [FR2K]	DLCI, LMI, and quality test

BACKGROUND MONITOR

• Modes	High impedance and during simulation
• Protocol analysis on-board	
• Programmable filters	Independent filters' capturing and displaying
• Statistics information	
• Analysis of the results stored on PC	PC108 for Windows™

AUTOMATIC ACCESS TEST

- Fully automated Access test
- Supplementary services automatic test
- Programmable test sequence

BIT ERROR RATE TEST

• G.821 statistics	ES, SES, US, DM, PASS/FAIL, S-LOSS
• Pseudo-Random bit sequences	User definable 2^{11-1} , 2^{15-1} , 2^{23-1} , All 0's, All 1's, 10101010, 16 bit octet, HDLC frame
• Error Injection	Manual, Automatic, Single

MANUAL SENDING

• Types	Bit, LFA, LOS, AIS, NMFAS, Sa, RAI (A bit), E bit, CRC, CV, control leads
---------	---

GENERATE TRAFFIC

• Number of cycles	Up to 65535
• Number of parallel calls	Up to 30 (PRI)
• Delay between calls	User selectable

X.25/X.31

• Modes	SVC, PVC
• Logical Types	DTE, DCE
• Tests	Traffic generator, Echo port

IP

• Modes	IP routed, IP over PPP (Client and Server)
• IP address supported	Static, Dynamic
• Authentication protocol ^{PPP}	PAP, CHAP (MD5)
• Protocols	IPv4, UDP, DNS, DHCP, ICMP, TFTP, HTTP, FTP

FRAME RELAY [FR2K]

• Frame Relay Forum	FRF.1.1, FRF.3.1, FRF.12.1, FRF.14
• Type of traffic	IP, IP over PPP
• LMI	ITU-T Q.933, ANSI T1.617, original LMI CISCO
• Logical Types	UNI, CPE, NNI
• QoS statistics	FECN, BECN, DE, NLPID, DLCI, FRF.12

U-BUS LOOP QUALIFICATION

- U-Bus voltage measurement
- Loop resistance measurement (Ω)
- Programmable simulation "NT-load" over U-Bus
- Activation/Deactivation time measurement (msec.)

HISTORY AND PREDEFINED TESTS FEATURES

Saving and recalling of 10 different setup and results for each kind of test

CONNECTORS

- Primary Access interface RJ45 120 Ω , BNC 75 Ω
- V.11/X.21 DB-15
- S/T Basic Access interface RJ45 (ISO 8877)
- U Basic Access interface RJ45 (ISO 8877)
- RS232 DB-9 (V.28 CCITT ISO4902)
- Handset 4 wires RJ9. Balanced, 600 Ω
- Power in External AC/DC adapter
- Power out Mini-DIN 4 wires connector

ENVIRONMENTAL CHARACTERISTICS

- Dimension
- Weight, with battery \approx 1 kg
- Dimensions, with holster (mm) 130 (w) x 260 (l) x 65 (d)
- Power
- Battery Type Rechargeable, Ni-MH
- Battery life \approx 3 hours @ 25°C, LCD back-lit off
- External AC/DC adapter 115/230Vac \pm 10% @ 50/60 Hz

TEMPERATURE

- Storage/Transport - 40°C to +70°C
- Operating, nominal - 5°C to +45°C
- Operating, limits -10°C to +55°C
- Humidity, non-condensing \leq 93% RH @ 40°C
 \leq 70% RH @ 55°C
- User's Safety Aspects EN 61010-1, EN 60950, EN 41003
- EMC Aspects EN 55022, EN55024, EN 61000-3-2 / -3-3
- CE Marking Class B (residential devices)

MISCELLANEOUS

- LCD display 240x200 Graphic display wide bright an back-lit
- Internal microphone & loudspeaker
- Upgradable firmware
- MultiMediaCard™ memory extension MMC2000 Option

OPTIONS

- INET2500 HTTP, FTP Internet download
- VX21-2500 X.21 / V.11 interface
- WT2000 So/To wiring test
- AB2000N Analog (POTS) line adapter
- LT-U2K BRI LT-U simulation
- D2022-Q BRI U (2B1Q) interface monitor
- D2022-T BRI U (4B3T) interface monitor
- MMC2000 MMC Memory extention
- VX2000 DTE/DCE Datacom tester
- FR2K Frame Relay test suite
- PC108XP EXPERT license More performing version for protocol analysis and remote management
- KCX21-DXE2500 X21/VII DTE/DCE CABLE KIT
- KCX2K-DTE Cable Kit for VX2000 DTE simulation mode
- KCX2K-DCE Cable Kit for VX2000 DCE simulation mode



23, avenue Roger Salengro
68100 MULHOUSE - FRANCE

Tél : +33 3 89 42 22 88

Fax : +33 3 89 42 30 31

www.telecom.fr / www.siptel.com
siptel@siptel.com